

# **FIREFLY VENTILATION SYSTEM PRODUCT INTRODUCTION**

Fan GD66.04D Series

## Fan GD66.04D Series

The fan is designed specifically for energy storage unit, battery charging rooms, other power batteries storage container, and fixed battery storage areas. It could be used in connection with combustible / toxic gas detection devices, BMS, and other control devices for protection of personnel's life and property safety. Eliminated hazards from hydrogen, other flammable, explosive, or toxic gases, and ensure the continuous and uninterrupted customer operation.



The Inlet fan and exhaust fan are used together as a perfect ventilation system to achieve the designed air movement of the protected area. Simple and reliable control can effectively and quickly to ventilate flammable, explosive, or toxic gases that may accumulate inside confined space out of the protected area. Air duct system may be required to fit the site condition.

The product is easily to install and fix; Both of Intake Electrical Louver and Exhaust Fan are equipped with IP55 electrical control device.

## Product Features

- ★ UL/CE international certification pusher.
- ★ Used in conjunction with combustible or toxic gas detectors.
- ★ Non continuous operation, the LED working status indicator light is on during operation.
- ★ Equipped with fan operation status feedback function.
- ★ Equipped with blade fault feedback function.
- ★ Lock when the air valve door panel is opened or closed.
- ★ Equipped with maintenance and self testing functions.

## Technical Specifications

Project	Parameters/Specifications	
Product model	GD62.31DJ13.D00	GD66.04DJ14.D00
Product name	Side Mounted Inlet fan	Top Mounted Exhaust Fan(fully open type)
Product size	460mm×460mm×52mm	590mm×510mm×131.8mm
Package dimension	532mm×532mm×105mm	652mm×572mm×180mm
Net weight	8.0kg	20.5kg
Gross weight	9.2kg	21.8kg
Product material	Carbon steel	
Appearance color	RAL9003	
Rated voltage	230VAC 50/60Hz	
Rated current	AVG 1300mA	
Air Volume	Inlet area: 0.042m <sup>2</sup>	
	Exhaust air volume: 820±15%CFM(1394±15% <sup>m</sup> ³/h)	
Fan certification	UL, CE, ATEX	
Pusher certification	UL, CE	
Blade drive mode	Pusher	
Open/Close duration	Open: 6S ± 1S Close: 6S ± 1S	
Storage temperature	-20°C~+60°C/85%RH	
Working temperature and humidity	-10°C~+50°C/85%RH	
Level	IP55	
Shell anti-corrosion grade	C5	
Installation hole size	405mmX405mm	535mmX455mm

## Dimensional Drawing of Top Mounted Exhaust Fan (fully open type) Unit : mm [inch]

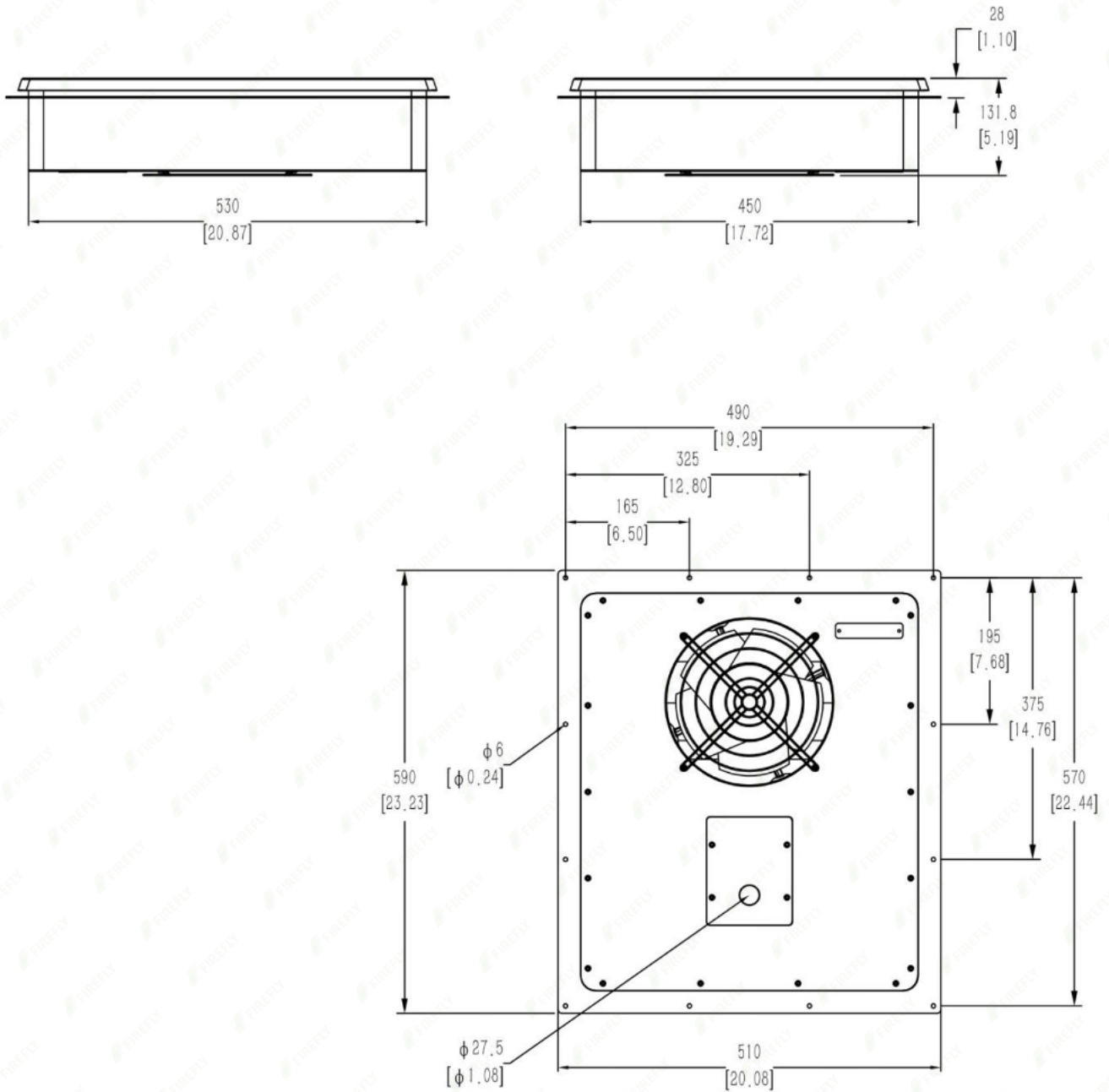

## Dimensional Drawing of Inlet Fan Unit : mm [inch]

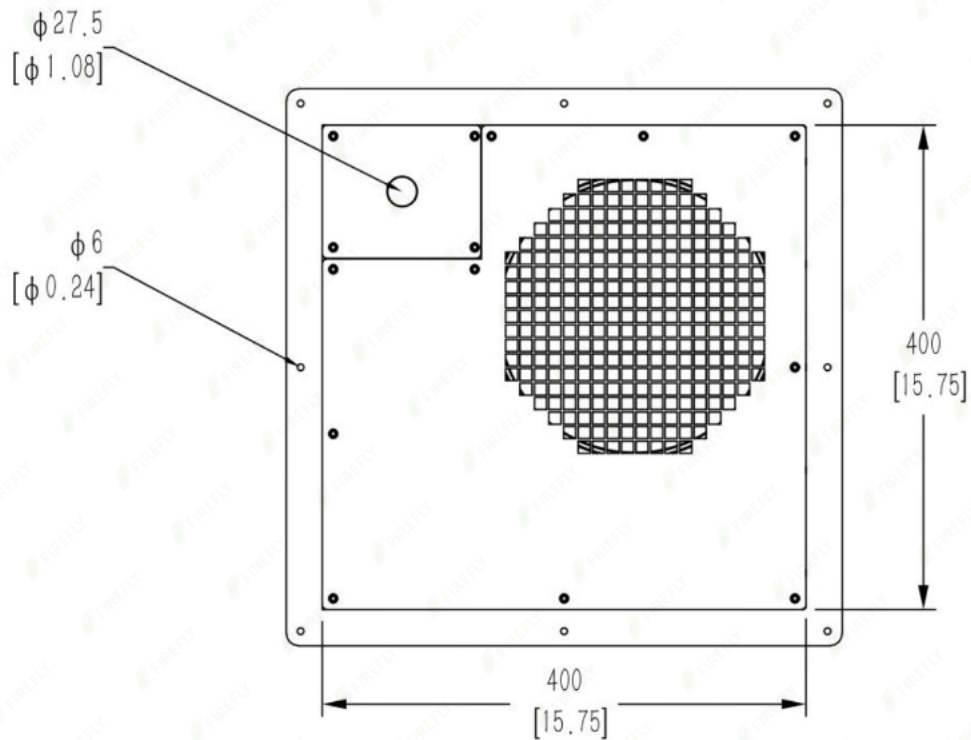
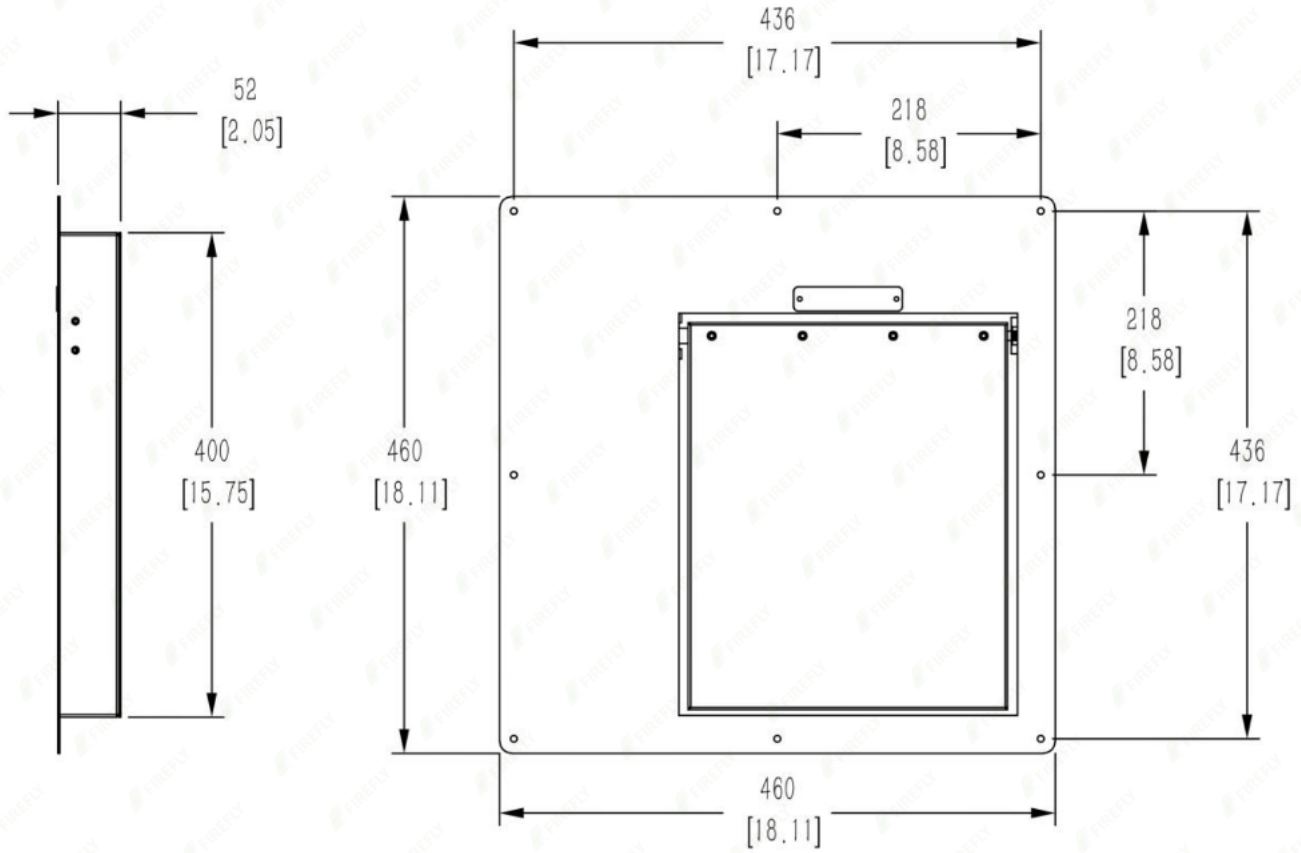

## Dimensional Drawing of Control Box Unit : mm [inch]

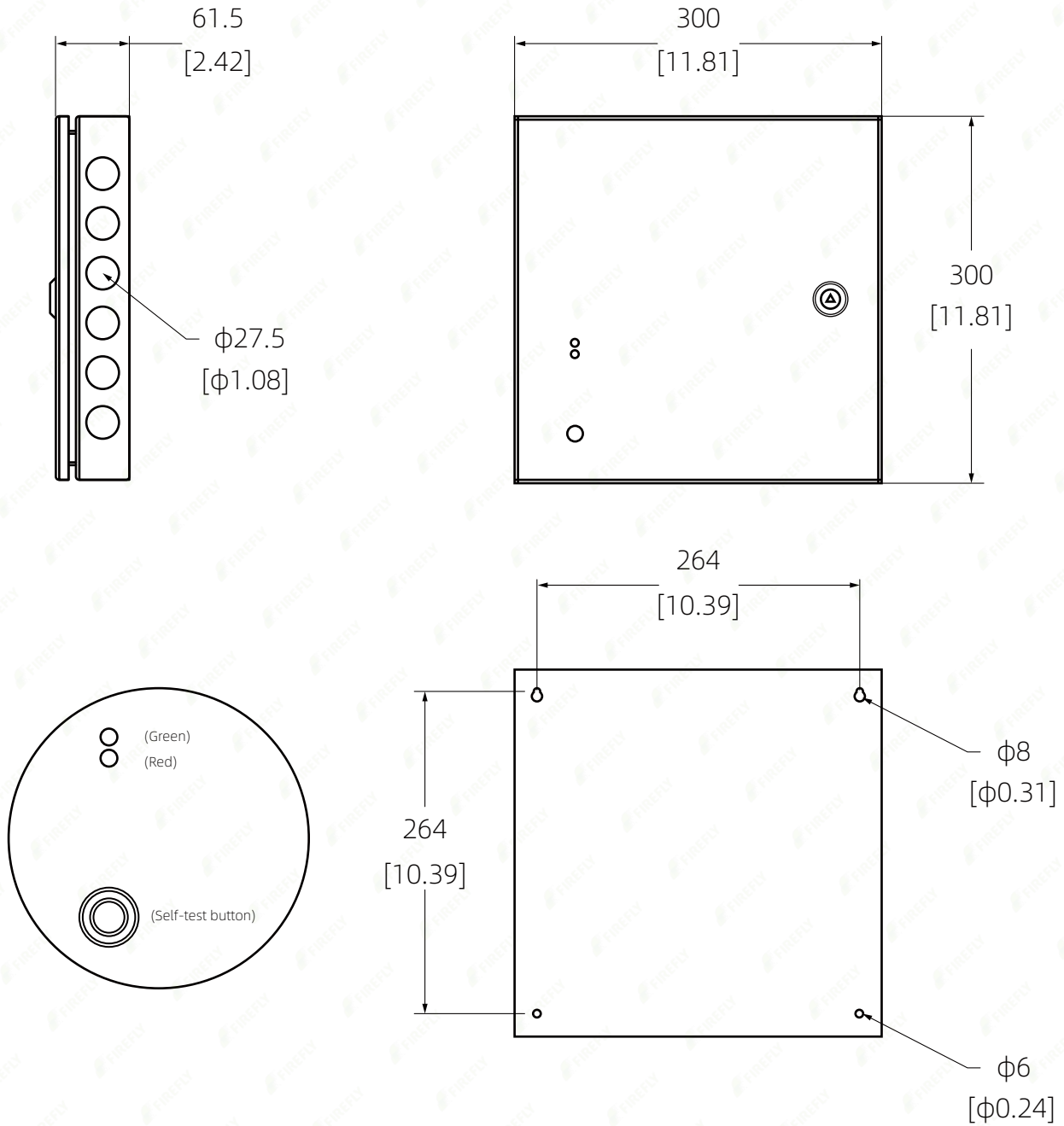

## Connections Description

Control PCB Connections Description							
Serial NO.	Terminal definition	Serial NO.	Terminal definition	Serial NO.	Terminal definition	Serial NO.	Terminal definition
1	Air-intake unit pusher -	11	Ventilation fan unit louver status input +	21	Manual start -	31	Earthing wire E
2	Reservation (actuator / stepping motor)	12	Ventilation fan unit louver status input -	22	Emergency stop +	32	Power supply AC/L
3	Reservation (actuator / stepping motor)	13	Actuated signal NO	23	Emergency stop -	33	Power supply AC/N
4	Air-intake unit pusher +	14	Actuated signal COM	24	Louvers fault signal -	34	Power supply DC/+
5	Air-intake unit louver status input +	15	Actuated signal NC	25	Louvers fault signal +	35	Power supply DC/-
6	Air-intake unit louver status input -	16	485B	26	Fan power supply AC/N	36	Fan power supply DC/+
7	Ventilation fan unit pusher -	17	485A	27	Fan power supply AC/L	37	Fan power supply DC/-
8	Reservation (actuator / stepping motor)	18	Gas alarm signal +	28	Main supply wire AC/N		
9	Reservation (actuator / stepping motor)	19	Gas alarm signal -	29	Main supply wire AC/L		
10	Ventilation fan unit pusher +	20	Manual start +	30	Earthing wire E		
<b>PCB Connection</b>							

Open Top Ventilation Fan Unit PCB Connections Description				
Serial NO.	Terminal definition	Serial NO.	Terminal definition	PCB Connection
1	Louver status signal -	5	/	
2	Louver status signal +	6	Pusher +	
3	Pusher -	7	Fan AC/N	
4	/	8	Fan AC/L	

### Air-Intake Unit PCB Connections Description

Serial NO.	Terminal definition	Serial NO.	Terminal definition	PCB Connection
1	Louver status signal -	5	Pusher -	
2	Louver status signal +	6	Pusher +	
3	/	7	Fan AC/N	
4	/	8	Fan AC/L	

### Wiring Diagram

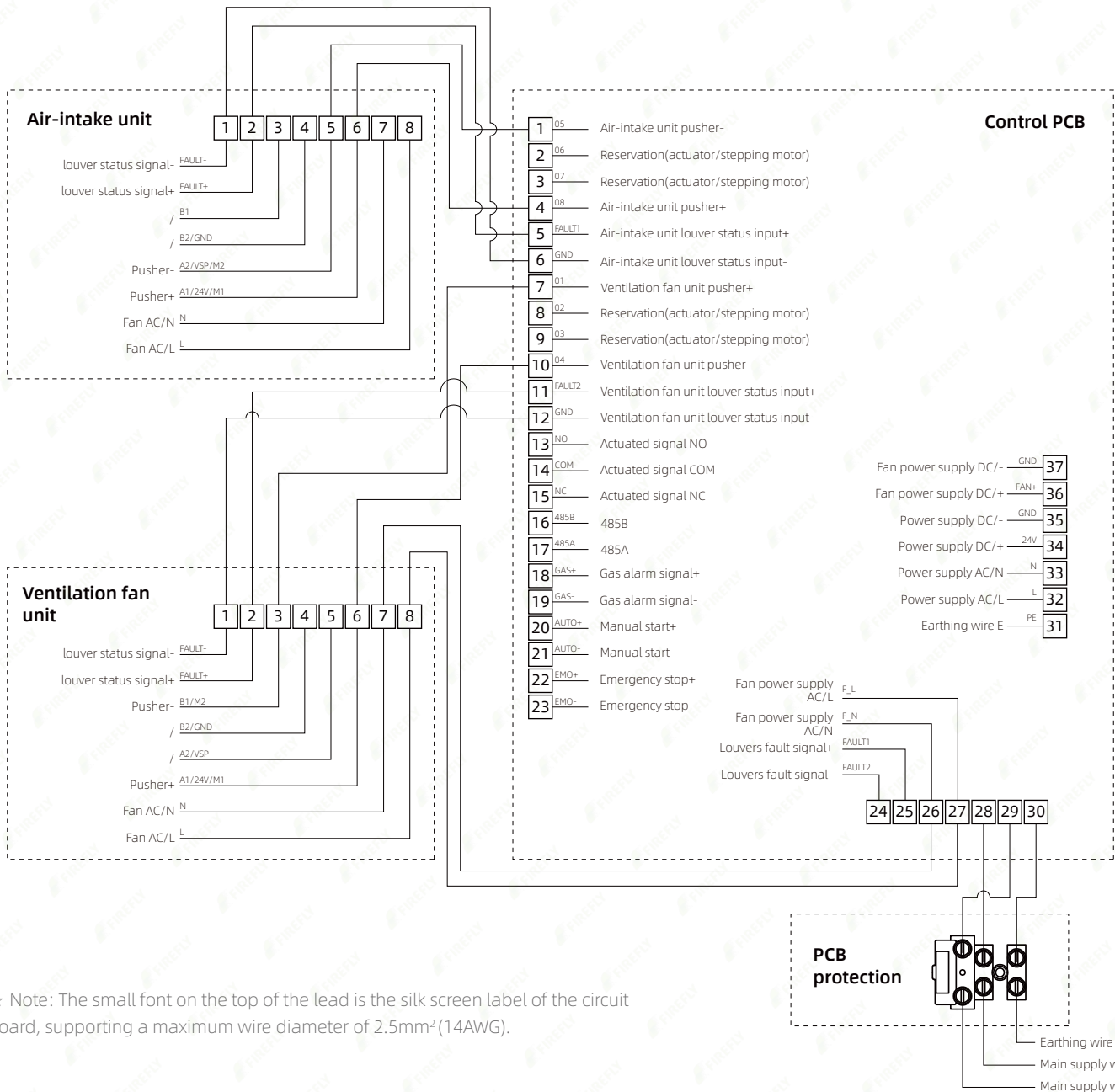

☆ Note: The small font on the top of the lead is the silk screen label of the circuit board, supporting a maximum wire diameter of 2.5mm<sup>2</sup> (14AWG).



**FIREFLY** Excellent Brand  
Under Wanzn Energy Safety

FireFly Global Sales & Distribution

## **FireFly Safety Limited**

**Address:** 19H Maxgrand Plaza No 3 Tai Yai St San Po Kong Hong Kong

**Tel:** 00852 4613 9499

**Email:** [Firefly@fire-fly.hk](mailto:Firefly@fire-fly.hk)

**Website:** [www.fire-fly.hk](http://www.fire-fly.hk)

※ ※ ※ Document version number :20251205-V1.5 ※ ※ ※

If you have any questions or need to obtain the latest information, please contact us.